

Farm Fuel Storage and Handling

Introduction

Both fuel and oil are frequently used on farms. As a result of their extensive use, the storage and handling of these petroleum products pose a risk to drinking water and aquatic habitats. Once in the groundwater, fuel will not naturally degrade. In fact, a litre (L) of fuel can render a million L of water unfit for drinking or irrigation. This factsheet provides information on the proper construction of a fuel storage area, as well as the responsible handling of petroleum products.

Siting and Construction of Storage Area

All petroleum storage areas should be located:

- **away from other stored chemicals and combustible materials;**
- **>30 m from wells (preferably downslope);**
- **>30 m from watercourses; and**
- **gasoline storages should be >15 m from an insured building**

Most insurance companies require tanks to be less than 15 years old. It is recommended that you check with your insurance company for siting restrictions and environmental cleanup coverage before constructing any fuel storage facility.

All fuel tanks should be ULC or CSA approved. Tanks should be placed on a reinforced concrete pad with posts or guardrails to protect them from vehicles. The concrete pad should extend 30 cm beyond the edge of the tanks to collect any drippings and enable visibility to all parts of the tanks (Fig. 1).



Fig.1. Fuel tanks on a concrete pad with protective posts.

Covered facilities with concrete floors and curbs are recommended if the fuel storage area has the potential to contaminate a watercourse or well. The curbed floor should be capable of holding a volume of 110% of the largest fuel tank. Covered storages also provide shade for the tank to reduce evaporative losses, decrease the weathering of hoses and provide storage for lubricants (Fig. 2).

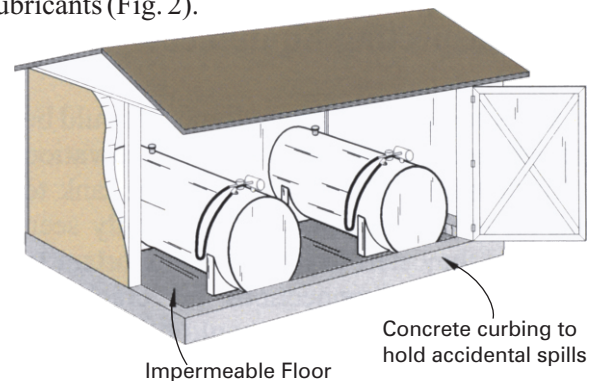

Fig.2. Cutaway view of fuel storage shed.

It is recommended that tanks not be placed on elevated structures due to their potential for accidental draining or toppling over.

Above ground tanks larger than 4000 L or underground storage tanks larger than 2000 L are regulated by the Nova Scotia Department of Environment and Labour. Regulations require these tanks to be installed by a licensed installer and all new tank installations of these sizes must have secondary containment (i.e. double walled tanks, dyking).

The proper selection of a ULC or CSA approved pump is important because most fuel spills are the result of:

- **Faulty automatic shutoffs;**
- **slow pump that people leave unattended; or**
- **hand pumps that overflow.**

Electric pumps should be able to fill the equipment in a short time thus ensuring someone is watching the tank as it is being filled. It is recommended that a security system be used to prevent spills due to vandalism or accidents. A switch or timer to turn off power to the pump or a lock can be used.

Inspecting Equipment

Fuel tanks and dispensing equipment should be inspected monthly by both visual observation and by running a hand underneath the tank to check for moisture. Tanks will generally seep fuel before they start to leak. It is important to check hoses and connections for cracks or stains. Leaking equipment should be replaced immediately. Do not overfill fuel tanks and allow for the expansion of fuel in hot weather.

A simple emergency preparedness and response plan should be established. As part of the plan, materials to absorb or contain an accidental spill (i.e. sawdust, kitty litter, spill kit) should be available at all times. Any spills greater than 100 L must be reported to the Nova Scotia Department of Environment and Labour (1-800-565-1633).

Furnace Oil Storage

Home furnace oil tanks should be placed on a solid base of poured concrete or concrete patio blocks. Fuel lines from tanks should extend from the top of the tank so it cannot drain if broken. A protective

shield should be placed over any fuel lines extending out of the bottom of a furnace oil tank.

Disposing of Used Oil, Filters and Tanks

Used oil should be returned to the point of purchase. Some retailers will also accept used oil filters. Another option for used oil filters is to drain them, place in a plastic bag and discard with regular roadside garbage pickup.

When replacing fuel tanks with new metal tanks, any fuel left in the old tank should not be transferred into the new tank as this fuel may contain contaminants, such as water or bacteria, which may accelerate corrosion of the new tank.

Old fuel tanks should be properly drained, have absorbent material placed in the bottom of the tank and be taken to the landfill or metal recycles. Regulated tanks must go to an approved facility. Care should be taken when working around old gasoline tanks.

Underground storage tanks installed prior to April 11, 1995, must be removed no later than 15 years after the date of installation by a licensed contractor. Overall, the installation of underground storage tanks is not recommended.

Portable Tanks

Fuel tanks used for irrigation pumps should have a wide base for stability and have a flexible fuel line attached to the top of the tank. It is recommended that these tanks have secondary containment. This could include double walled tanks with a fuel line connected to the top of the fuel tank. Another option is to place the tanks on a concrete pad with a concrete curb capable of holding a volume of 110% of the tank size. A drain that can be locked, should be installed in the curb. It is critical that the drain be closed when the tank is placed in the concrete structure in the summer time. This will reduce the risk of fuel entering the ground or irrigation source if the tank was to be vandalized. Where possible, protect the fuel line or use a high strength line such as hydraulic hose as the fuel line is the most susceptible area for an accidental break or vandalism. Portable tanks larger than 450 L are required to be inspected annually.